

THIS DRAWING IS UNPUBLISHED. RELEASED FOR PUBLICATION
 © COPYRIGHT - By - ALL RIGHTS RESERVED.

LOC	DIST	REVISIONS					
CM	00	P	LTR	DESCRIPTION	DATE	DWN	APVD
			H5	REVISED PER ECO-11-020968	18OCT11	JR	SM

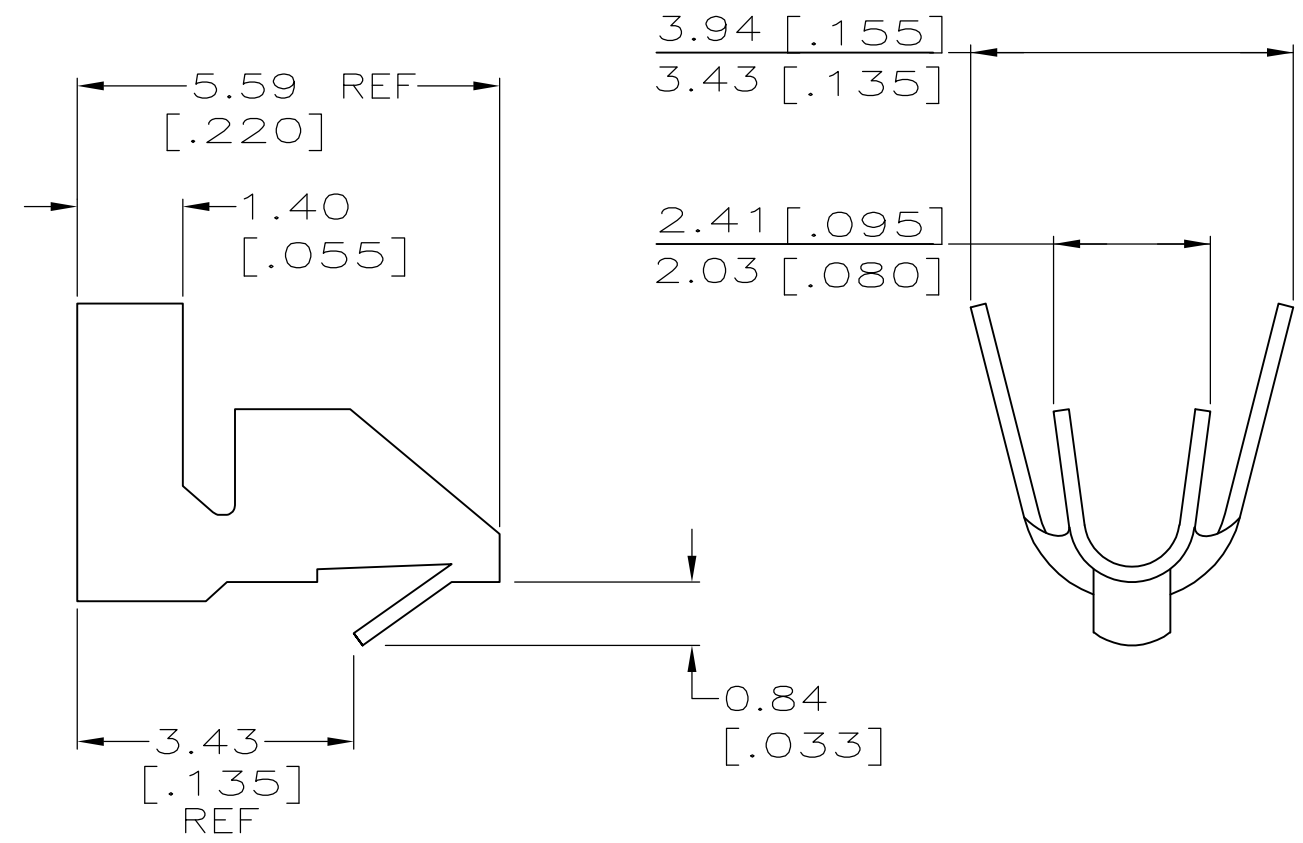

- PARTS COMPLY WITH AMP SOLDERABILITY SPEC 109-11-3.
- WIRE RANGE: 0.3 - 0.9 mm² (22 - 18 AWG).
- INSULATION RANGE: 1.52 - 2.79 [.060 - .110] DIA.
- 0.00254 [.000100] MIN BRIGHT TIN-LEAD OVER 0.00203 [.000080] MIN MATTE COPPER.
- 0.00508 [.000200] MIN BRIGHT TIN-LEAD.
- DIMENSIONS IN BRACKETS ARE IN INCHES.
- FOR FOREIGN PRODUCTION ONLY.
- 4µm [.00016] MIN BRIGHT TIN PLATING.
- HOLE DIAMETER TO BE 1.83±0.08 FOR WIRE 0.3-0.6mm2 (20-22 AWG) OR 1.96±0.08 FOR WIRE 0.8-0.9mm2 (18 AWG).

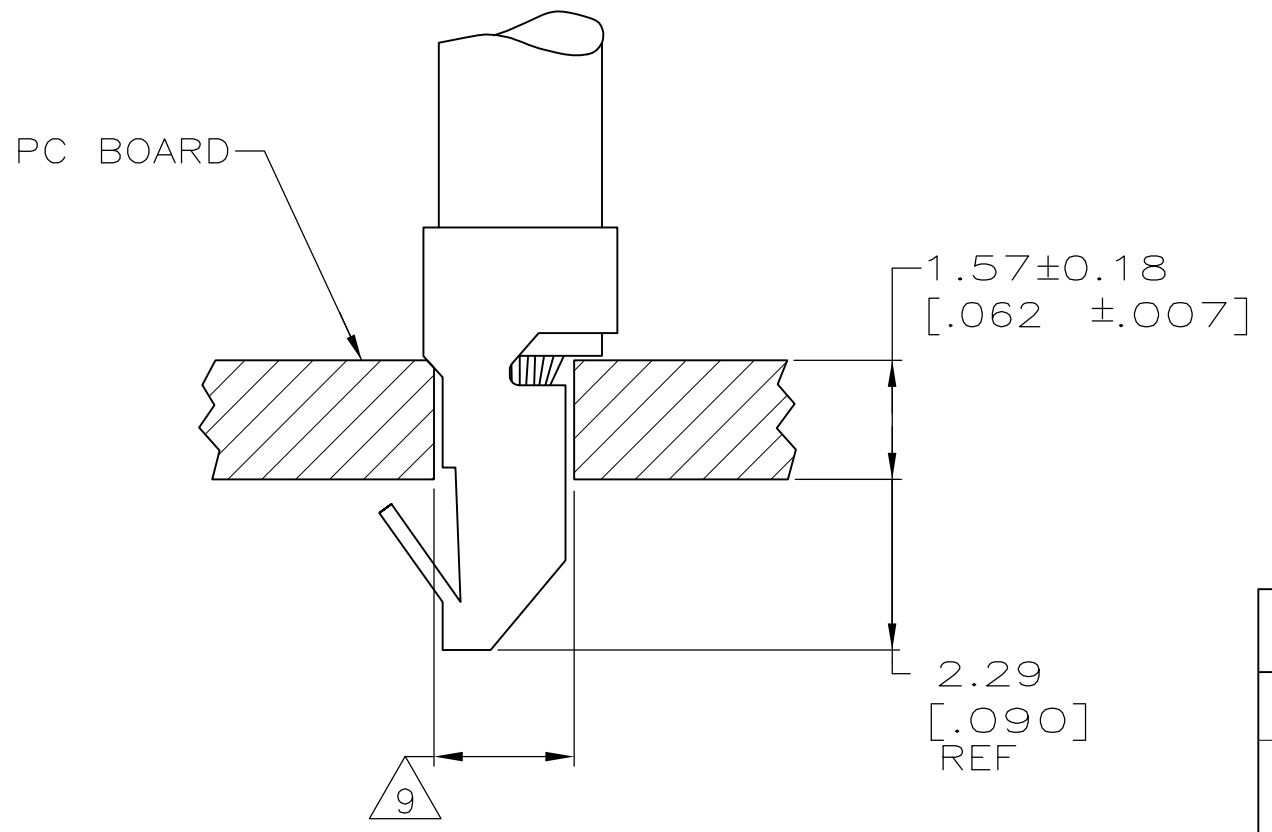

8	0.20[.008] PHOS BRONZE	3-770565-2
8	0.20[.008] BRASS	3-770565-1
4 7	0.20[.008] BRASS	770565-3
5	0.20[.008] PHOS BRONZE	770565-2
4	0.20[.008] BRASS	770565-1
FINISH	MATERIAL	PART NUMBER

THIS DRAWING IS A CONTROLLED DOCUMENT.

DWN B. LEWIS	12-20-89	STE TE Connectivity	NAME MINI AMP-IN			
CHK R. SWING	12-21-89					
APVD W. LONG	12-21-89					
PRODUCT SPEC						
APPLICATION SPEC		SIZE	CAGE CODE	DRAWING NO	RESTRICTED TO	
		A3	00779	C-770565		
MATERIAL SEE TABLE	FINISH SEE TABLE	CUSTOMER DRAWING		SCALE 10:1	SHEET 1 OF 1	REV H5